

VOYAGER HIGH EFFICIENCY GAS FIRED WATER HEATER SSVH SERIES

COMBINATION DOMESTIC HOT WATER HEATING & RADIANT FLOORS, WALLS, OR CEILINGS!

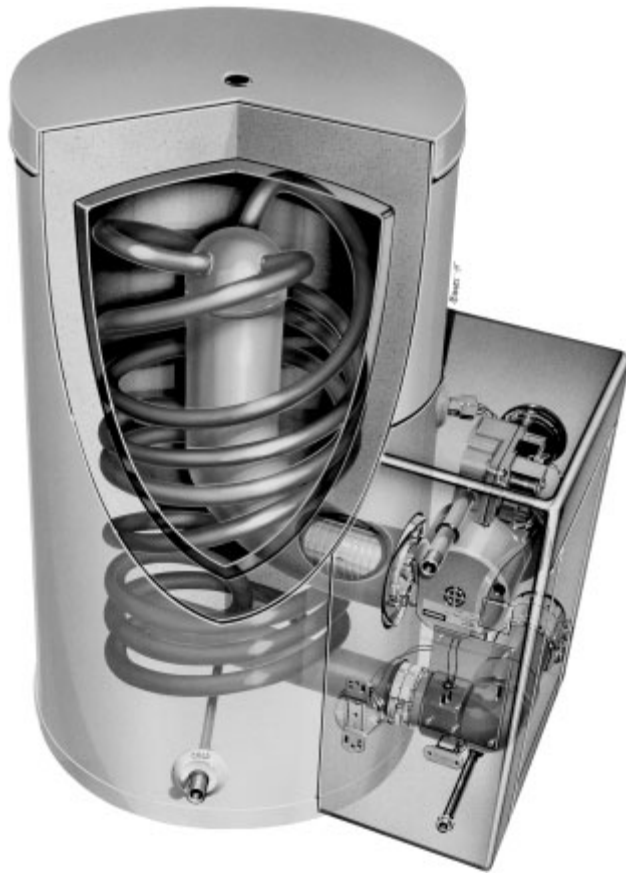

Introducing the Voyager SSVH model, a 95% efficient, combination heating/hot water heater! The Voyager SSVH model appliance is a truly unique heating appliance which will provide endless new opportunities for you and your customer.

Each Voyager SSVH model is designed with the most advanced technology available for a natural/propane gas appliance. This use of modern technology optimizes the efficiency and operating reliability of each Voyager SSVH model.

The endless features will provide each customer with maximum savings on operation, space, and installation!
Increase your profits and save your customers money by installing a Voyager SSVH model today \$\$\$\$



*Heat Transfer Products, Inc., reserves the right to make product changes or updates with or without notice.
Heat Transfer Products will not be held liable for typographical errors in literature. For questions, please consult the factory.*

IMPORTANT INSTRUCTIONS FOR SSVH MODELS

HOW THE SYSTEM WORKS WITH RADIANT HEAT:

SSVH models are very efficient and powerful water heating devices. The Voyager SSVH models produce larger amounts of hot water in a very small compact design when compared with conventional water heaters. Heat Transfer Products has designed the Voyager SSVH model exclusively as a combined hot water/radiant space water heater. The units are built with a secondary heat exchanger to transfer heat from the stored water into the circulating loop for the floor, ceiling, or baseboard radiant system. This secondary heat exchanger allows the Voyager SSVH model to heat both the domestic water and provide output to the heating loop by installation of a re-circulation line connected from the domestic hot water outlet to the domestic cold water inlet, to get the rated capacity of the secondary heat exchanger to the heating loop. The Voyager SSVH130 model can transfer up to 110,000 BTU's in the secondary heat exchanger and also deliver 180 gallons of hot water in the first hour of operation. Another important feature is that the SSVH models have the ability to direct vent with a zero clearance tolerance to any combustible surface which enables the Voyager to be installed virtually anywhere! This type of power, efficiency, and installation flexibility in the SSVH model appliances is a Voyager exclusive that no other water heater manufacturer can offer!

HOW THE SYSTEM WORKS WITH HEATING/COOLING:

The SSVH models can work in connection with air handling equipment off potable water storage tank, to provide air or radiant heating, cooling, and domestic hot water. These types of systems provide the advantage of zoned heating and cooling, which provide much greater comfort and operating efficiency versus conventional systems.

HOW TO INSTALL THE SYSTEM:

Enclosed you will find sample drawings which can provide you with ideas on how to lay out the system. The use of a mixing valve is always recommended to achieve flexibility in adjusting temperature to meet the system demand.



NOTE:

IT IS VERY IMPORTANT TO FOLLOW EITHER LOCAL OR FEDERAL PLUMBING CODES WHEN INSTALLING AND OPERATING A MIXING VALVE FOR A DOMESTIC HOT WATER SYSTEM! FOR SET POINT TEMPERATURES ABOVE 120 DEGREES F., YOU MUST USE AN ANTI-SCALD TEMPERING VALVE ON THE OUTLET TO DOMESTIC HOT WATER FIXTURES.

It is essential to read the Voyager installation manual to assure proper operation of the Voyager system. Areas in the manual that need special attention are condensate removal, venting of combustion gasses, and connection of a bronze circulator between the domestic hot water outlet, domestic cold water inlet.

HOW TO SIZE THE COMBINATION SYSTEM FOR RADIANT HEATING:

It is important to size both the heating load and the domestic hot water load in choosing which Voyager SSVH model you will need to purchase for the job. On the following page is a chart which represents the design outputs of the secondary heat exchanger in the Voyager SSVH model. This chart outlines the output characteristics in terms of flow rate through the **secondary heat exchanger**, temperature rise, and BTU output. It is important to check with your radiant equipment supplier on the output temperature, design temperature rise or delta tee, and the total BTU output required for the job.



VERY IMPORTANT:

IT IS IMPORTANT THAT THE PUMP IS SIZED CORRECTLY TO THE PRESSURE DROP CURVE OF THE SECONDARY HEAT EXCHANGER. MATCH THE PUMP SIZE BY UTILIZING CHART "A" ON PAGE 4.

A bronze circulator between the domestic hot water outlet and the domestic cold water inlet is required and supplied with unit! Once you have determined your system output requirements, refer to the Voyager SSVH model sizing chart on page 3 to determine the model and flow rate required through the secondary heat exchanger, in order to meet the loads of the system. Examples are provided to guide you through the selection process. Once we know that the secondary heat exchanger has been sized correctly to meet the radiant BTU load, we must now look into the hot water load.

First you need to understand the difference between first draw capacity and first hour capacity. First draw capacity is established as the time frame at different output rates which the Voyager SSVH model can deliver the desired temperature before the tank rate input and storage are consumed. This usually occurs when there is a larger draw of hot water in a very short time frame. (Example: Hot tub 80 gallon with a fill rate of 10 minutes) First hour rating is established as a rating system to compare the water heater's ability to recover over a one hour period. The first hour rating can be very misleading when the hot water load is required in a very short period of time.

Now we can determine which Voyager SSVH model will suit your needs for the job. To do this, refer to the domestic hot water chart. If the domestic hot water demands exceed the Voyager SSVH's capacity, then a storage re-circulation tank can be installed to meet the system hot water load. After you have sized your domestic load and heating load, you are now ready to choose the Voyager SSVH model for the job.



NOTE:

A BRONZE CIRCULATOR BETWEEN THE DOMESTIC HOT WATER OUTLET AND THE DOMESTIC COLD WATER INLET IS REQUIRED (AND INCLUDED) TO ACHIEVE RATINGS ON FOLLOWING PAGE.

*SECONDARY HEAT EXCHANGER SIZING

**Secondary Heat Exch.
Recommended Flow**

Rate (GPM)	Temperature rise (degrees F.)			
	15 deg. F.	20 deg. F.	25 deg. F.	30 deg. F.
2	15,000	20,000	25,000	30,000
3	22,500	30,000	37,500	45,000
4	30,000	40,000	50,000	60,000
5	37,500	50,000	62,500	75,000
6	45,000	60,000	75,000	90,000*
7	52,500	70,000	87,500*	105,000*
8	60,000	80,000	100,000*	N/R
9	71,400**	95,200**	119,000**	124,500**
10	85,000**	113,250**	140,000**	140,000**

* FOR SSVH130-45S MODELS ONLY!

** FOR SSVH199-80R MODELS ONLY!



VERY IMPORTANT:

The Voyager domestic storage temperature must be set 25 degrees F. above the system design temperature! (Example: Voyager set at 160 deg. F. will deliver 135 deg. F. to the heating loop. The above chart is based on using the circulator between the domestic cold water inlet and the domestic hot water outlet.



NOTE: For set point temperatures above 120 degrees F., you must use an anti-scald tempering valve on the outlet of the Voyager to assure delivered temperature does not exceed 120 deg. F. to domestic hot water fixtures.

VOYAGER FIRST DOMESTIC WATER DRAW CAPACITY (In minutes) AT 140 DEG. F.

Model	2 GPM	3 GPM	4 GPM	5 GPM	6 GPM	7 GPM	8 GPM
SSVH90-45S	20	15	9	7	5	4	3
SSVH130-45S	20	16	12	10	9	7	6
SSVH199-80R	00	00	15	14	13	12	10

VOYAGER FIRST DOMESTIC WATER DRAW CAPACITY (In minutes) AT 115 DEG. F.

Model	2 GPM	3 GPM	4 GPM	5 GPM	6 GPM	7 GPM	8 GPM
SSVH90-45S	30	23	14	10	8	6	5
SSVH130-45S	31	24	18	16	14	11	10
SSVH199-80R	00	00	23	21	20	18	15

SPECIFICATIONS

MODEL	HEIGHT	WIDTH	DEPTH	INPUT	FIRST HR. RATING
SSVH90-45S	42"	24"	32"	90,000	125 U.S. gallons
SSVH130-45S	42"	24"	32"	130,000	180 U.S. gallons
SSVH199-80R	72"	24"	32"	199,000	300 U.S. gallons

MODEL	HEAT EXCH.	HEAT EXCH. BTU	RECOVERY	VENT	WEIGHT
SSVH90-45S	32 Sq. Ft.	81,000	95%	3"	205 Lbs.
SSVH130-45S	32 Sq. Ft.	110,000	94%	3"	205 Lbs.
SSVH199-80R	32 Sq. Ft.	140,000	94%	3"	255 Lbs.

TANK LAYOUT - 45 GALLON SSVH

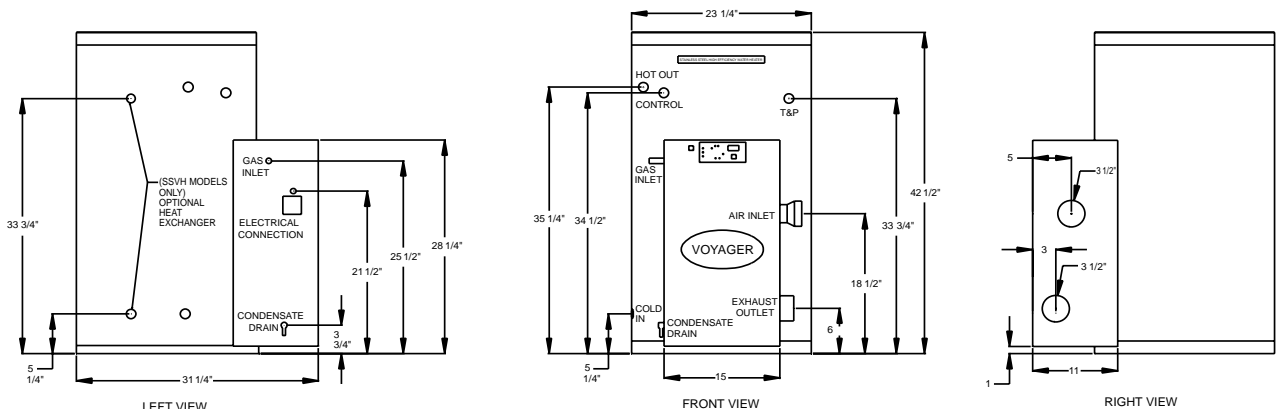

TANK LAYOUT - 80 GALLON SSVH

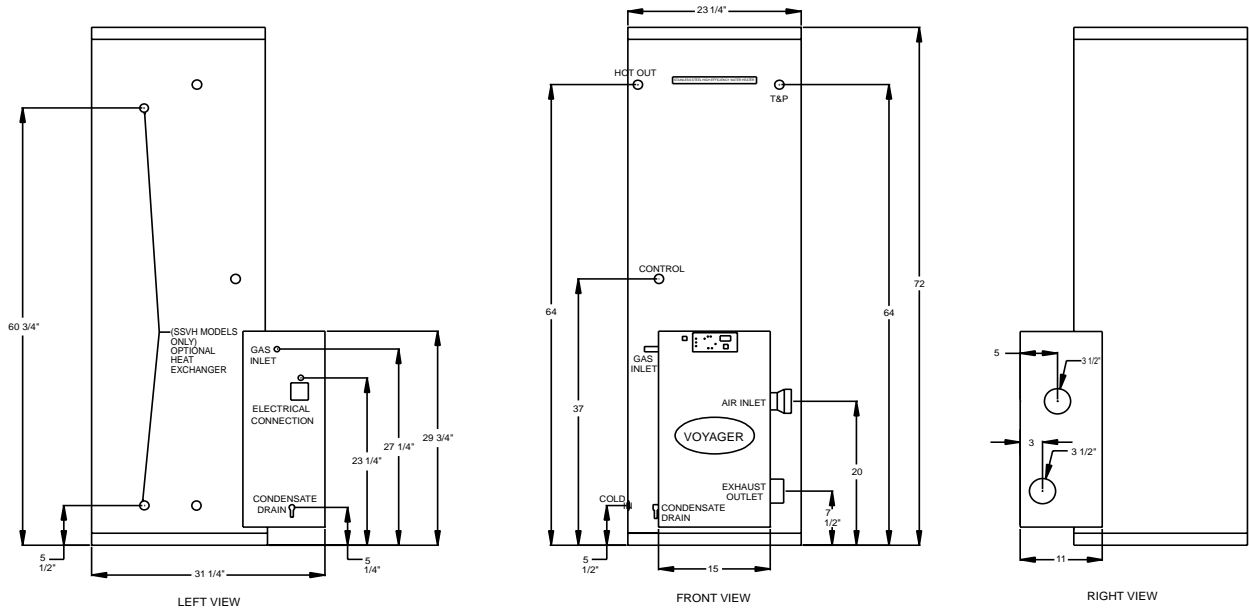

COMBINATION HEATING, COOLING, AND DOMESTIC HOT WATER HEATING WITH RADIANT LOOP FOR HEATING WITH ADDITIONAL STORAGE

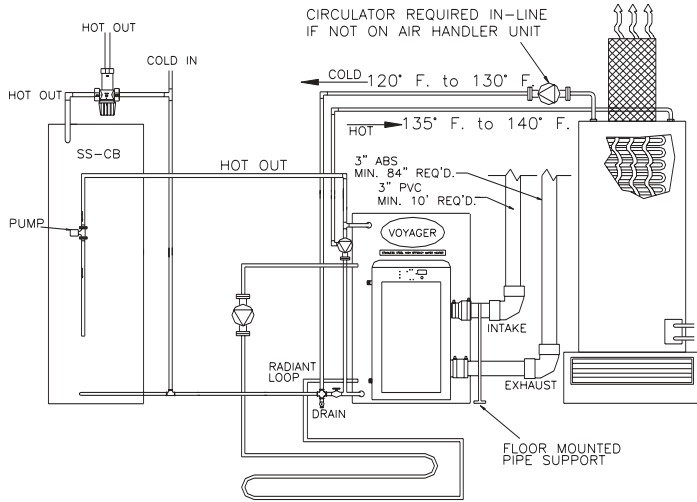

COMBINATION HEATING, COOLING, AND DOMESTIC HOT WATER HEATING WITH RADIANT LOOP FOR HEATING

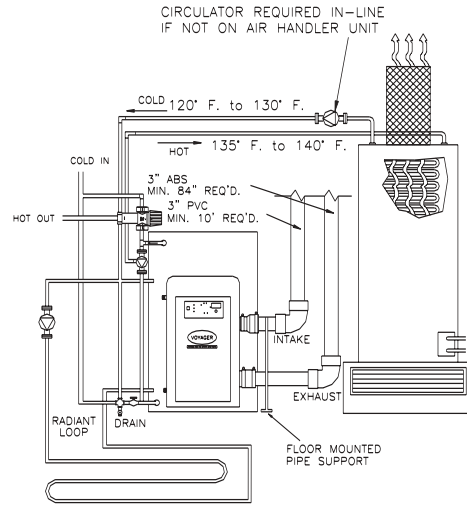

COMBINATION WATER HEATING AND FLOOR RADIANT HEATING WITH VOYAGER AS CLOSED LOOP HEAT SOURCE

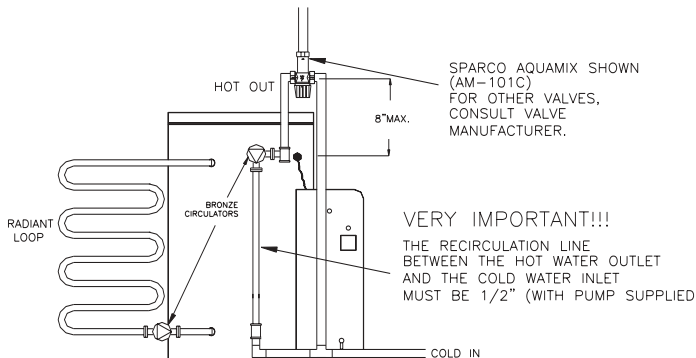

CHART "A" SECONDARY HEAT EXCHANGER PRESSURE DROP

